

The Ganymede Commander 101



User Manual

1	INTRODUCTION	1
2	PRINCIPLE OF OPERATION.....	1
3	NORMAL OPERATION.....	4
4	INSTALLATION.....	5
4.1	UNIVERSAL MODE	6
	Echostar Configuration	6
	Mediamaster Configuration	6
	Commander Installation.....	6
4.2	NON-UNIVERSAL MODE	8
	Echostar Configuration	8
	Mediamaster Configuration	8
	Commander Installation.....	9
4.3	EXPERT MODE.....	11
	Echostar Configuration	11
	Mediamaster Configuration	11
	Commander Installation.....	12
5	PROGRAMMING THE COMMANDER	13
	DiSEqC Program Codes.....	14
	Changing a Satellite id	14
	Extended Program Codes.....	15
	Setting The Operating Mode.....	15
	Setting the Echostar Remote Control Address.....	15
	Setting IR Test Mode	16
	Master Reset.....	16

1 INTRODUCTION

The Ganymede Receiver Commander 101 enables you to integrate a digital receiver into your existing motorised system controlled by an Echostar LT 8700 receiver/positioner.

These instructions refer specifically to the Nokia Mediamaster (9200/9500/9600) free to air receivers running FTA1.0 and later versions of software. If you have a different digital receiver, you will need to adapt these instructions accordingly.

Please read these instructions carefully before connecting your Ganymede Commander. A full understanding of the principles of operation is essential before installation.

2 PRINCIPLE OF OPERATION

The commander utilises outputs from the Nokia and Echostar receivers to allow the Echostar to automate dish movement and band/polarity switching for digital channels.

The commander utilises the following data signals:-

- (a) DiSEqC codes, 22kHz tone and 13/18 voltage levels. These are available at the IF input of the Nokia receiver via an external power inserter.
- (b) 0/12Volt Auxiliary output on the Nokia.
- (c) Dish motor pulse obtainable from the Echostar.
- (d) An infrared command link to the Echostar.

Data (a) is used to obtain satellite, LNB band and polarity information. This is sent to the Echostar via the IR link.

Depending on the mode of operation, data (b) is either used for LNB band selection or to extend the effective number of DiSEqC satellites from four to eight.

Data (c) is used to establish that the dish movement is complete before subsequent commands are issued.

Effective use of the above data requires that the Nokia be correctly programmed regarding antenna name, band, polarity, 12Volt output and LNB frequency.

Except when used with a universal LNB, selection of LNB band and polarity is undertaken via the Echostar which must be configured so that channels 1 to 4 on each satellite provide the required combination ie:

- | | |
|----------------------------|-----------------------------|
| CH 1 = Low band Vertical | CH 2 = High band Vertical |
| CH 3 = Low band Horizontal | CH 4 = High band Horizontal |

The commander supports three modes of integrated operation as follows:-

UNIVERSAL. For use with a universal LNB and smart priority switch where only dish positioning is required. In this mode the commander will use the available four DiSEqC codes in conjunction with the auxiliary 12Volt output to instruct the Echostar receiver to move the dish to one of eight positions.

NON-UNIVERSAL. For use where dish/band/polarity changes are required with installations using a quad LNB and ferro-magnetic or mechanical polariser. In this mode the commander will instruct the Echostar to move the dish to one of four positions and then set the correct band and polarity. In this case the 12Volt auxiliary output is used to set the LNB band.

EXPERT. For use only by customers with access to a Nokia settings editor such as 'SETEDIT', and detailed knowledge of how to re-program the Nokia firmware. This mode offers the highest level of integrated operation giving access of up to eight dish positions as well as LNB band and polariser switching.

The Commander is factory pre-set to respond to DiSEqC switching messages with the following Echostar satellite id's:

DiSEqC Code	LT8700 Satellite id	Satellite
1	22	Astra 19.2° E
2	24	Hotbird 13° E
3	31	Thor/Intelsat 707 1° W
4	41	Intelsat 605 27.5° W

Table 1.1
Default Satellite ID's – All Modes

In 'Universal' or 'Expert' mode, the following pre-sets are also available:

DiSEqC Code	0/12V	LT8700 Satellite id	Satellite
1	12V	27	Sirius 5° E
2	12V	18	Astra 2 28.8° E
3	12V	25	Eutelsat 2F3 10° E
4	12V	-	Not Factory Pre-set

Table 1.2
Additional Satellite ID's – 'Universal' and 'Expert' Modes Only

Depending on your preferred satellites and also on your level of LT8700 firmware, you may need to re-program some or all of these satellite id's. Re-programming is described in the Section 5.

As well as satellite id's, the operating mode and the Echostar remote control address are also re-programmable by the user.

An IR Test Mode and Master Reset are also provided.

The Commander uses two push buttons and two LED's for control and indication:

Button 1:	Program	This button puts the commander into program mode for changing various settings. It is only used during installation.
Button 2:	Motor Control/ Set	This is a dual function button. During normal operation, it is used to toggle Motor Control on and off. In programming mode, it is used to enter data.
LED 1:	Power On	This LED is normally on – indicating that the unit is powered and operational. The LED blinks slowly whenever the commander transmits to the LT 8700. It blinks fast when the commander detects that the dish motor is running.
LED 2:	Motor Control	This LED is on during normal operation. It is extinguished whenever Motor Control is disabled by operation of the 'Motor Control' button.
LED's 1 and 2 also serve during program mode to indicate respectively when buttons 1 and 2 are pressed.		

3 NORMAL OPERATION

Once your Commander is configured and installed, follow these simple instructions for viewing digital and analogue channels and for finding new ones.

<p>To view an analogue channel:</p>	<p>Ensure that your digital receiver is in stand-by. Use your LT 8700 to select the wanted analogue channel.</p>
<p>To view a Digital channel on a DiSEqC satellite:</p>	<p>Ensure that the LT8700 is powered up before powering up the digital receiver. Select the wanted digital channel. The Commander will automatically select the correct satellite, band and polarity.</p>
<p>To view a Digital channel on a non-DiSEqC satellite:</p>	<p>Ensure that the LT8700 is powered up before powering up the digital receiver. Select the wanted digital channel and manually move the dish to the correct satellite. The Commander will automatically select the correct band and polarity. Note: Alternatively, you can move the dish <i>before</i> you select the digital channel.</p>
<p>To search for new digital channels</p>	<p>Ensure that the LT8700 is powered up before powering up the digital receiver. Disable Motor Control by pressing the Commander's 'Motor Control' button once. (This prevents the Commander from repeatedly moving your dish as you step between satellites in the Nokia search screen). Manually move the dish to the wanted satellite. Use the Nokia channel search menus to find and store the new channels. Be sure to select the correct antenna for the satellite you have manually moved to. During channel search, the Commander will automatically set LNB band and polarity as instructed by the digital receiver. Restore Motor Control by pressing the 'Motor Control' Button when you are ready to return to normal viewing.</p>

4 INSTALLATION

The commander is supplied with three captive leads and a separate motor pulse lead. Additionally, a power inserter is required. This can be obtained from Ganymede Test & Measurement. Note that a specially modified power inserter is required if you wish to use the Commander in **Universal** mode. (see next section)

There are many ways in which the receivers can be interconnected; the recommended options shown below will allow a correct operation of the Commander. Other methods of interconnection may be preferable in your particular installation.

It is an advantage to have the Echostar on-screen graphics available in order to monitor operation of the Commander. This is particularly useful when the Commander issues a dish movement instruction since the OSG give you feed back about what is happening.

These installation notes assume that your LT8700 is already set up and functioning normally as an analogue receiver/ positioner.

Depending on the mode of operation chosen it will be necessary to configure either or both receivers.

4.1 UNIVERSAL MODE

Echostar Configuration

No configuration changes are required to the Echostar. However you may wish to route the Nokia Video via the Echostar in order to view the Echostar on-screen graphics during digital viewing.

Mediamaster Configuration

The Mediamaster must be configured to send the correct DiSEqC messages and 12V auxiliary signal for each of its eight antennas. To do this, enter the antenna configuration screen by selecting:

Menu -> Installation -> Antenna Configuration

From this screen, set up the antennas according to your preferences. The following table gives a suggested layout.

Each DiSEqC code can be used twice – once with 0V and once with 12V, giving total of eight usable codes.

Note that the satellite names are merely labels to identify the antennas when you are in the channel search menus. Because Nokia only give a limited choice of satellite names, you may have to use an incorrect name for the satellite you want (eg Sirius is used for Intelsat 605 in the example table).

If you wish to view more than eight satellites, then you must assign one antenna for non-DiSEqC use. Name this antenna (say) ‘Other 1’ and set the DiSEqC selection to ‘Min A’.

Antenna Number	1	2	3	4	5	6	7	8
Satellite Name	Astra (Astra)	Hotbird (Hotbird)	Thor (Thor)	Sirius (Intelsat 605)	Sirius (Sirius)	Astra (Astra 2)	Hotbird (Eutelsat 2F3)	Other 1
LNB Frequency	Universal	Universal	Universal	Universal	Universal	Universal	Universal	Universal
0/12 Volt	0	0	0	0	12	12	12	12
DiSEqC Selection	DiSEqC 1	DiSEqC 2	DiSEqC 3	DiSEqC 4	DiSEqC 1	DiSEqC 2	DiSEqC 3	Min A*

* ‘Min A’ prevents the Commander from issuing a move dish command.

Note that in the channel search screens, the ‘antennas’ are identified by the satellite names you assigned in the previous section.

Commander Installation

Figure 1 shows the interconnections between the Commander and other system components.

The Power Inserter is a special version of the Global Communications DCBF which has been modified to pass power through to the Universal LNB. This is obtainable from Ganymede Test & Measurement.

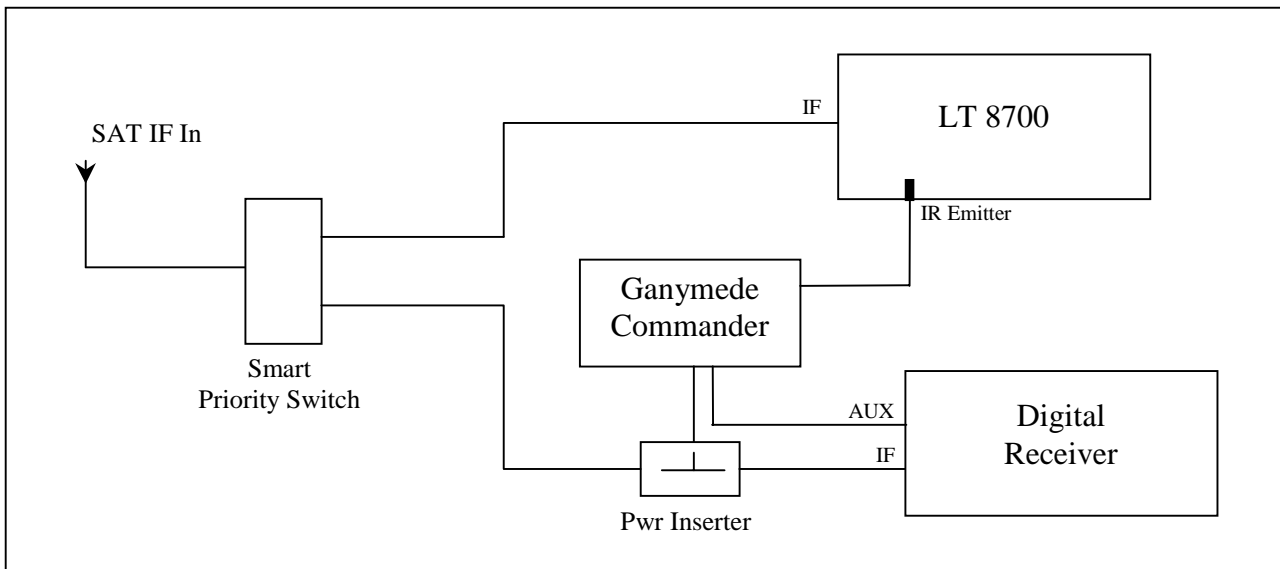

Figure 1
Interconnect Diagram – Universal Mode

1. Connect the power inserter between the Nokia input and RF cable.
2. Plug the 3.5mm Jack Plug into the power inserter.
3. Plug the Phono connector into the 0/12 volt socket at the rear of the Nokia.
4. Approximately align the blue IR emitter with the Echostar's IR receiver and attach it to the front panel with the sticky pad provided. The emitter has a circular lens on one face; this face should point towards the Echostar. The Echostar's IR receiver is located 155mm from the right hand edge and can be seen through the Perspex front panel.
5. Switch the Nokia on and confirm that the LED's on the commander light up.
6. Identify which remote control address your Echostar uses, if this is not 0 (factory default), re-program the commander with the correct address. This is described in the Section 5.
7. Whilst viewing the Echostar TV output, test the IR path to the Echostar by entering IR Test Mode (extended program code 5- see Section 5). The upper LED will flash continuously and the Echostar's current channel information should flash on and off the screen. If this does not happen, check that you have set the right address and that you have positioned the IR emitter correctly.
8. The test mode is cancelled by switching the Nokia to stand-by and back on again.

This completes physical installation of the commander.

Note the motor control lead is not used in the universal mode.

When a digital channel is selected the commander will instruct the Echostar to select the required dish movement.

4.2 NON-UNIVERSAL MODE

Echostar Configuration

In this mode, you need to reconfigure the Echostar so that the first four channels for each satellite are set to the correct band and polarity for digital reception.

Before you start, you may wish to move some or all of your existing channels that use those channel slots. You can do this with the 'Add a Channel' command in the 'Change Memory' menu.

Once you have done this, go to each satellite in turn and, using the 'Tune' menu:

set channel 1 to low band Vertical
set channel 2 to high band Vertical
set channel 3 to low band Horizontal
set channel 4 to high band Horizontal

Note: If you are using a ferro-magnetic polariser, it is advisable to set a mid-band frequency for each of the four channels. This will minimise any polariser errors due to the frequency dependency of this type of polariser.

It is advisable to route the Nokia Video via the Echostar in order to view the Echostar on-screen graphics during digital viewing.

Mediamaster Configuration

The Mediamaster must be configured to send the correct DiSEqC messages and 12V auxiliary signal for each of its eight antennas. To do this, enter the antenna configuration screen by selecting:

Menu -> Installation -> Antenna Configuration

From this screen, set up the antennas according to your preferences. The following table gives a suggested layout.

Note that you will need to use two antenna positions for any satellite with both low and high band digital channels (eg Hotbird).

Set the 0/12 Volt switched output to 0V for each low band antenna; and 12V for each high band antenna.

Note also the satellite names are merely labels to identify the antennas when you are in the channel search menus. Because Nokia only give a limited choice of satellite names, you may have to use an incorrect name for the satellite you want (eg Sirius is used for Intelsat 605 in the example table).

Always reserve two antennas for 'Other 1' and 'Other 2' which should be set to low band and high band respectively. These are used view any satellite for which you have not assigned a DiSEqC code. The DiSEqC selection for these positions should be 'Min A'.

Antenna Number	1	2	3	4	5	6	7	8
Satellite Name	Astra (Astra)	Hotbird (Hotbird)	Thor (Thor)	Sirius (Intelsat 605)	Hotbird (Hotbird)	Other 1	Other 2	Not Used
LNB Frequency	10.750	10.750	9.750	9.750	9.750	9.750	10.750	-
0/12 Volt	12	12	0	0	0	0	12	-
DiSEqC Selection	DiSEqC 1	DiSEqC 2	DiSEqC 3	DiSEqC 4	DiSEqC 2	Min A*	Min A*	-

* 'Min A' prevents the Commander from issuing a move dish command.

Note that in the channel search screens, the 'antennas' are identified by the satellite names you assigned in the previous section.

Commander Installation

Figure 2 shows the interconnections between the Commander and other system components.

The Power Inserter/DC Block must be connected the correct way round as shown in the diagram.

The LNB is powered and controlled by the LT8700. Therefore the splitter used has to be capable of passing power through the leg connected to the LT 8700. The second leg does not have to pass power, but it does not matter if it does.

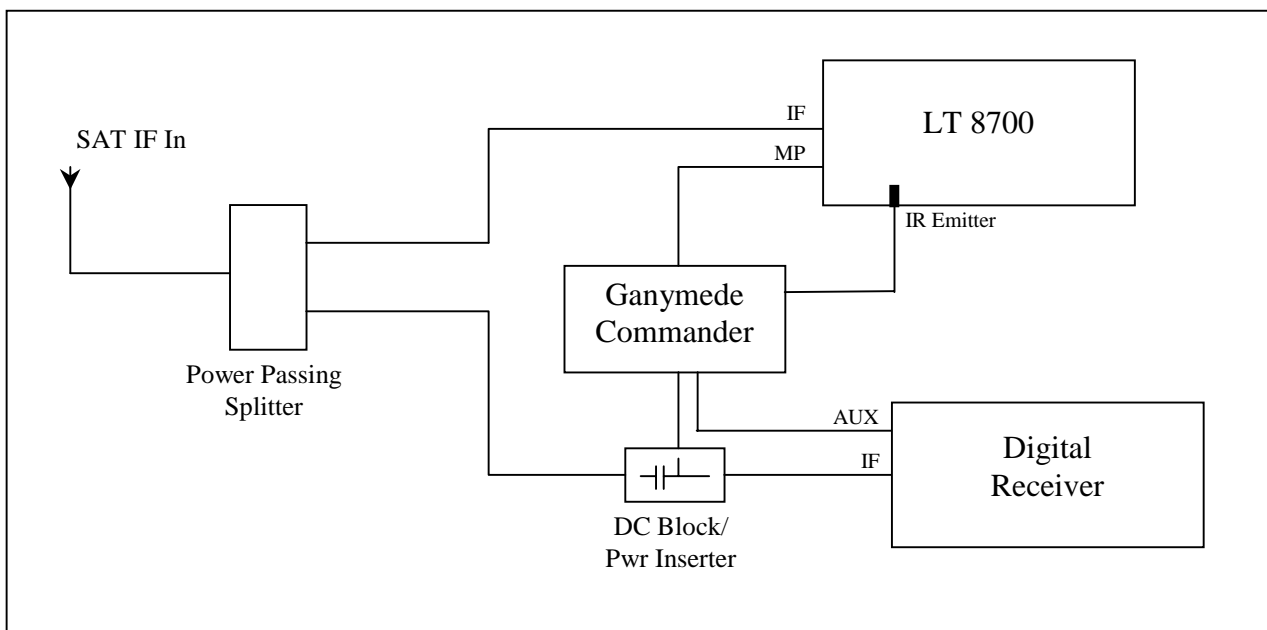

Figure 2
Interconnect Diagram – Non-Universal (and Expert) Mode

1. Connect the power inserter between the Nokia input and RF cable.
2. Plug the 3.5mm Jack Plug into the power inserter.
3. Plug the Phono connector into the 0/12 volt socket at the rear of the Nokia.
4. Approximately align the blue IR emitter with the Echostar's IR receiver and attach it to the front panel with the sticky pad provided. The emitter has a circular lens on one face; this face should point towards the Echostar. The Echostar's IR receiver is located 155mm from the right hand edge and can be seen through the Perspex front panel.
5. Connect the Motor Pulse cable to the rear terminal block on the LT8700. The centre conductor (red insulation) goes to terminal B3 labelled 'Actuator Pulse'. The outer conductor goes to the ground terminal that is adjacent to it. **Be sure to connect these conductors the correct way round.**
6. Switch the Nokia on and confirm that the LED's on the commander light up.
7. Program the Commander to Non-Universal operating mode (Mode 2) as described in Section 5.
8. Identify which remote control address your Echostar uses, if this is not 0 (factory default), re-program the commander with the correct address. This is also described in the Section 5.
9. Whilst viewing the Echostar TV output, test the IR path to the Echostar by entering IR Test Mode (extended program code 5- see Section 5). The upper LED will flash continuously and the Echostar's current channel information should flash on and off the screen. If this does not happen, check that you have set the right address and that you have positioned the IR emitter correctly.
10. The test mode is cancelled by switching the Nokia to stand-by and back on again.

This completes physical installation of the commander.

When a digital channel is selected the commander will instruct the Echostar to select the required dish movement. On completion of the dish movement, the commander will select the appropriate channel to set LNB band and polarity.

Additionally, if you manually move the dish (say to a non-DiSEqC satellite) the Commander will set LNB band and polarity when the dish movement ceases.

4.3 EXPERT MODE

Expert mode requires you to use one of the freeware Nokia Settings Editor programs such as 'SETEDIT'. This is required because the current versions of Nokia firmware do not support dual band LNB's other than universal type with an upper LO frequency of 10.600 GHz.

If your LNB has a different upper LO frequency (eg 10.750 GHz) then you can use a settings editor to change the value stored in the Nokia. However, in order to effect this change, you will need to use a BDM interface and attach it to the BDM interface socket mounted inside the Nokia case. **You should be aware that this will void your Nokia warranty. Moreover, if you make a mistake whilst re-programming the settings, you could possibly end up with a non-working receiver. You should therefore only attempt this if you are absolutely sure of what you are doing.**

Echostar Configuration

The Echostar should be configured as for the **Non-Universal** mode above.

Mediamaster Configuration

In expert mode, the Nokia can only be configured using a PC based settings editor program; and the settings uploaded via the BDM interface.

Warning; do not undertake this procedure unless you are absolutely sure of what you are doing.

The eight antennas should be set up according to your preferences. The following table gives a suggested layout.

Note that, depending on your Nokia firmware version, the satellite names may not be stored correctly.

If you wish to view more than eight satellites, then you must assign one antenna for non-DiSEqC use. Name this antenna (say) 'Other 1' and set the DiSEqC selection to 'Min A'.

Antenna Number	1	2	3	4	5	6	7	8
Satellite Name	Astra (Astra)	Hotbird (Hotbird)	Thor (Thor)	Sirius (Intelsat 605)	Sirius (Sirius)	Astra (Astra 2)	Hotbird (Eutelsat 2F3)	Other 1
LNB Frequency	9.750/10.750	9.750/10.750	9.750/10.750	9.750/10.750	9.750/10.750	9.750/10.750	9.750/10.750	9.750/10.750
0/12 Volt	0	0	0	0	12	12	12	12
DiSEqC Selection	DiSEqC 1	DiSEqC 2	DiSEqC 3	DiSEqC 4	DiSEqC 1	DiSEqC 2	DiSEqC 3	Min A*

* 'Min A' prevents the Commander from issuing a move dish command.

Note that in the channel search screens, the ‘antennas’ are identified by the satellite names you assigned in the previous section.

Commander Installation

Connect up the Commander as described in the **Non-Universal** Mode set up section (Diagram 2) except that in Step 7, set the operating mode to ‘Expert’ (Mode 3).

When a digital channel is selected the commander will instruct the Echostar to select the required dish movement. On completion of the dish movement, the commander will select the appropriate channel to set LNB band and polarity.

Additionally, if you manually move the dish (say to a non-DiSEqC satellite) the commander will set LNB band and polarity when the dish movement ceases.

5 PROGRAMMING THE COMMANDER

Commands are entered via the two push buttons - 'PROGRAM' and 'SET'.

The Commander supports two programming modes as follows:

DiSEqC Program Mode is used to re-program DiSEqC satellite id's.

Extended Program Mode is used for all other functions.

To put the Commander into **DiSEqC Program Mode**:

Press the 'PROGRAM' button **once**. (Both LED's extinguish)

To put the Commander into **Extended Program Mode**:

Press the 'PROGRAM' button **twice**. (Both LED's extinguish)

In either mode, to enter a numerical value, N:

1. Press the 'SET' button **N times**. (The upper LED will flash each time you press the 'SET' button).
2. Press the 'PROGRAM' to confirm the entry. (The lower LED will flash when you press the 'PROGRAM' button.)

Throughout the user manual, the following shorthand notation is used to indicate programming sequences:

SET(N)	means	press the 'SET' button N times
PROGRAM(N)	means	press the 'PROGRAM' button N times

DiSEqC Program Codes

Table 2 shows the DiSEqC Program Codes available on the Commander. The greyed out codes are only applicable in 'Universal' or 'Expert' modes.

DiSEqC Program Code	Function
1	Change Satellite id for DiSEqC 1
2	Change Satellite id for DiSEqC 2
3	Change Satellite id for DiSEqC 3
4	Change Satellite id for DiSEqC 4
5	Change Satellite id for DiSEqC 1 (+12V)
6	Change Satellite id for DiSEqC 2 (+12V)
7	Change Satellite id for DiSEqC 3 (+12V)
8	Change Satellite id for DiSEqC 4 (+12V)

Table 2
DiSEqC Programming Codes

Changing a Satellite id

If your wanted satellite id's are different from the default values, you can change them using the following procedure.

The procedure uses the Echostar 'Select Satellite' screen to give visual feedback of what you have entered. Make sure that the Echostar is powered on and that you are viewing its output on your TV when you perform this procedure.

1. With both the digital receiver and the LT 8700 switched on, enter the DiSEqC Program Code for the DiSEqC satellite you wish to change. For example, to change DiSEqC code 3, enter:

PROGRAM SET(3) PROGRAM

The Echostar will open the 'Select Satellite' screen, and the flashing arrow will indicate the currently selected satellite for the DiSEqC code you entered.

2. Enter the new satellite id you wish to program. For example to set satellite id 25 enter:

SET(2) PROGRAM SET(5) PROGRAM

The Echostar will indicate the newly selected satellite with the flashing arrow.

(If you made a mistake, simply repeat this step again.)

3. To confirm the selection, enter **PROGRAM** again.

Extended Program Codes

Table 3 shows the Extended Program Codes available on the Commander.

Extended Program Code	Function
1	Set 'UNIVERSAL' Operating Mode
2	Set 'NON-UNIVERSAL' Operating Mode
3	Set 'EXPERT' Operating Mode
4	Change Echostar Remote Control Address
5	IR Test Mode
9	Master Reset: Restore all factory defaults

Table 3
Extended Programming Codes

Setting The Operating Mode

Extended Program Codes 1 to 3 are used to set the operating mode. Thus:

For Universal mode enter: **PROGRAM(2) SET(1) PROGRAM**

For Non-Universal mode enter: **PROGRAM(2) SET(2) PROGRAM**

For Expert mode enter: **PROGRAM(2) SET(3) PROGRAM**

Setting the Echostar Remote Control Address.

Extended Program Code 4 enables you to change the remote control address that the commander uses. The commander is factory set to the Echostar default address of 0. If you have changed your Echostar's address (for example to avoid interference from a neighbour's LT8700) then you will need to alter the Commander's address to match.

1. Enter the Extended Program code 4:

PROGRAM(2) SET(4) PROGRAM

2. Enter the new remote control address you wish to set. For example to set remote control address 2, enter:

SET(2) PROGRAM

Setting IR Test Mode

The IR test function is provided to enable you to optimise the position of the infrared emitter. In IR test mode, the Commander continuously sends the 'View' command to the Echostar causing it to flash the currently selected channel information on and off the TV screen. You should fix the emitter at a point which gives the most reliable operation.

To enable IR Test Mode, enter Extended Program Code 5:

PROGRAM(2) SET(5) PROGRAM

To cancel IR Test Mode, switch the digital receiver to standby and back on again.

Master Reset

Entering the Master Reset code causes the Commander to revert to its factory default settings:

To generate a master reset, enter Extended Program code 9 by pressing:

PROGRAM(2) SET(9) PROGRAM